

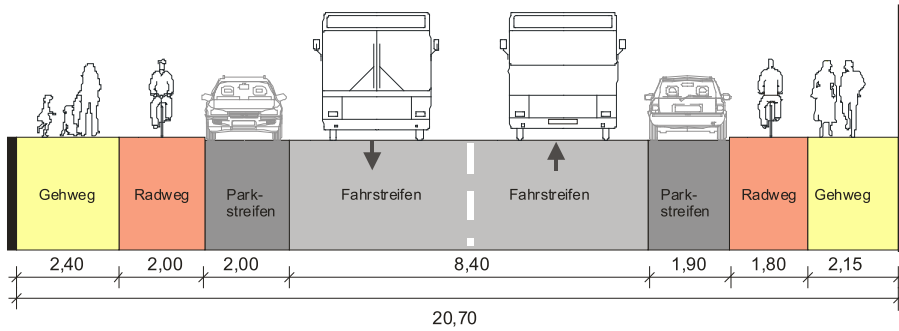

STADT ASCHAFFENBURG

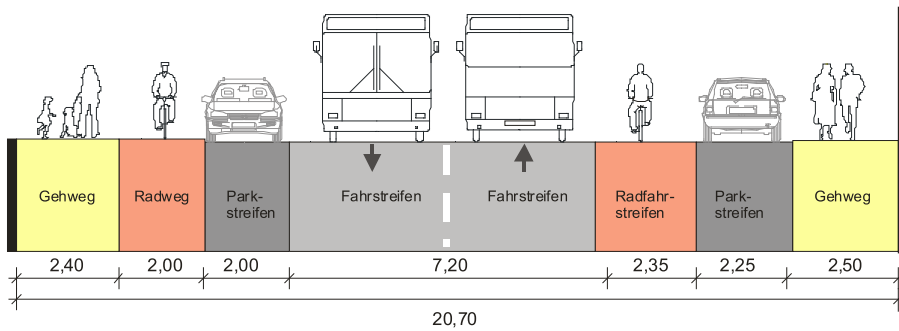

Bestand



**Konzept 1
Tempo 30**

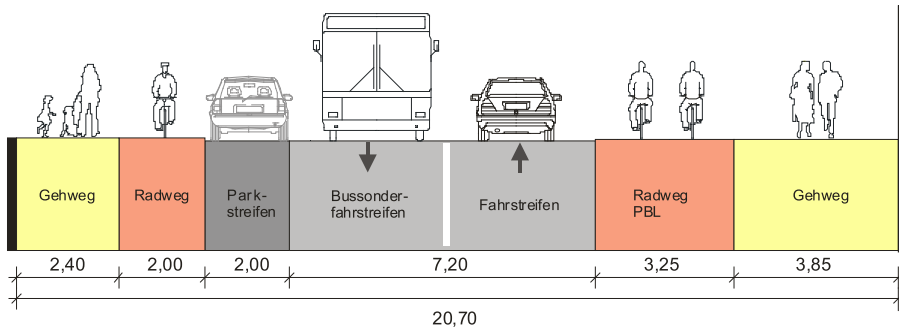

**Konzept 2
Einbahnstraßenring**

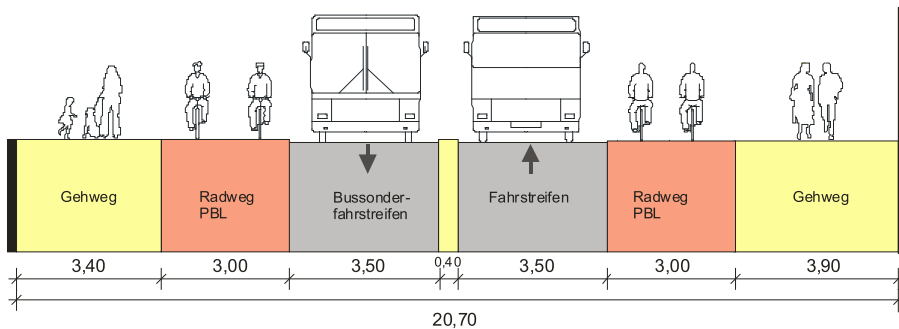

**Konzept 3
Umweltzone /
Unterbrechung**

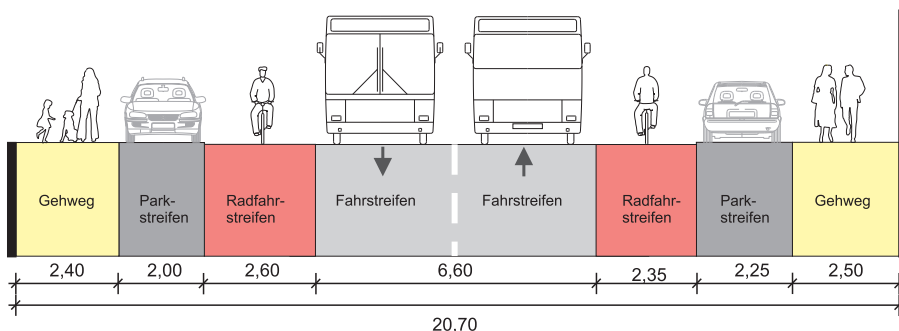

**Konzept 1+
Kombinations-
variante**